

TECHNICAL SPECIFICATION

FENCE TYPE
SAUDI ARAMCO SECURITY FENCE TYPE-5

POSTS AND PIPES
 ALL FENCE POSTS AND PIPES COMPLYING WITH ASTM A-53 SCH 40, PRE-GALVANIZED WITH AN AVERAGE ZINC COATING OF 450 GR/M2.

ITEM	POST LENGTH	OUTSIDE DIA(MM)	WALL THICKNESS	WEIGHT Kg/M
LINE POST	3400	60.3	3.91	5.44
CORNER, END AND STRAINING POST	3400	73.0	5.16	8.65
BRACE RAIL/STRUT	2900	42.2	3.56	3.39

FITTINGS
 ALL FENCE FITTINGS TO BE HOT-DIPPED GALVANIZED AFTER MANUFACTURE.

WIRE PRODUCTS
 1. WIRE FOR CHAIN LINK FABRIC GALVANIZED AS PER ASTM A-392.
 2. TENSION, STIRRUP AND TIE WIRE GALVANIZED A-641 CLASS-1.

CLASS	CHAIN LINK FABRIC		TENSION WIRE	STIRRUP WIRE	TYING WIRE	BARBED WIRE
	MESH	WIRE DIA				
B	50	3.76	4.5	3.0	2.5	-

NOTES
 1. ALL DIMENSION ARE IN mm, UNLESS NOTED OTHERWISE.
 2. ALL RESPONSIBILITIES FOR CONCRETE FOUNDATIONS ARE WITH THE CONTRACTOR.
 3. CONCRETE BEAM, POST FOUNDATION, REBARS & WRAPING TAPING BY OTHERS.
 4. ALL M10 BOLT/NUT ARE CARRIAGE BOLT/NUT.

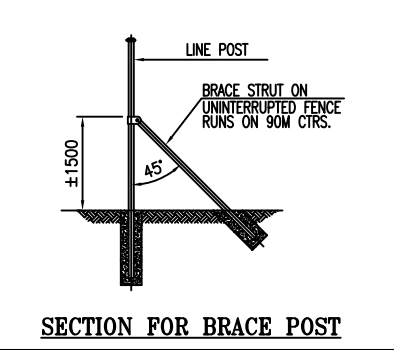
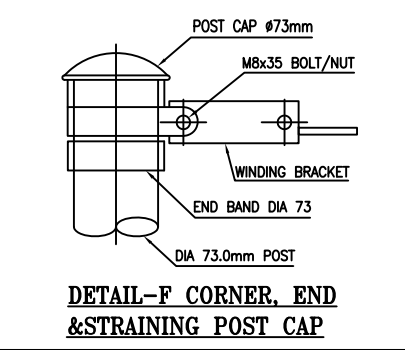
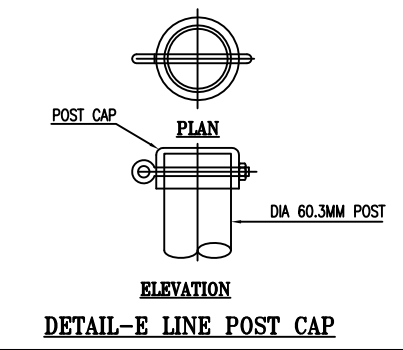
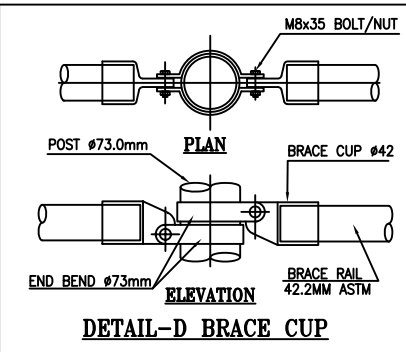
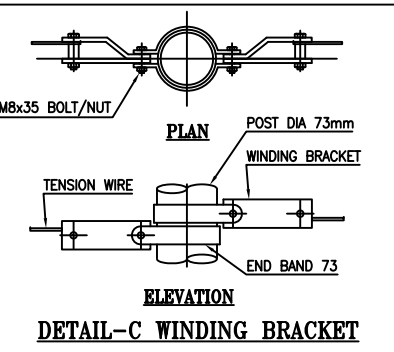
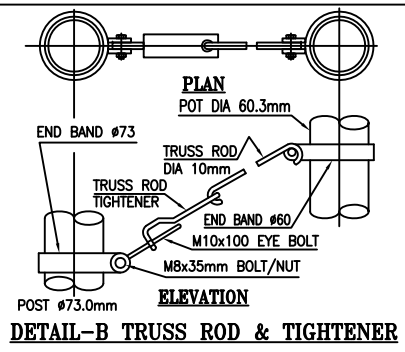
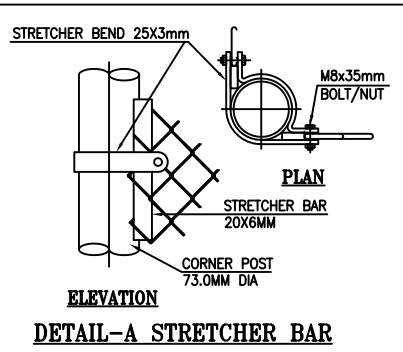

FINISH CLASS B
 1. ALL FENCE FITTING MATERIALS OF GOOD COMMERCIAL QUALITY GALVANIZED AFTER MANUFACTURE.
 2. CHAINLINK FABRIC, TENSION, STIRRUP AND TIE WIRE ARE GALVANIZED

APPROVED:	M.Z	CLIENT:	-
DESIGNED:	F.A	FENCE TYPE	SAUDI ARAMCO SECURITY FENCE TYPE-5
DRAWN:	M.T	TITLE:	-

GOLDEN FENCE MECHANICAL FACTORY
 P.O.BOX 36323 JUBAIL 31961 TEL : +96613 3408020
 KINGDOM OF SAUDI ARABIA FAX : +96613 3408022
 INFO@GOLDENFENCE.COM WWW.GOLDENFENCE.COM

DATE	DRAWING NO.	REV.
		1