

## TECHNICAL SPECIFICATION

FENCE TYPE  
**2700-B6TR (PVC) CATEGORY-1 WITH 3 ROWS BTC**

### POSTS AND PIPES

- ALL SCH.80 POSTS AND PIPES COMPLYING WITH ASTM F1083 WITH SPECIFICATION F1043 GROUP 1A HOT-DIP GALV. 500-550 GR/M2 PVC COATED. YIELD STRENGTH 83000 PSI (TENSILE STRENGTH 85000 PSI).
- ALL BRACE/TOP RAIL AND STRUT SCH.40 POSTS AND PIPES COMPLYING WITH ASTM F1083 WITH SPECIFICATION F1043 GROUP 1A PRE-GALV. 400-450 GR/M2 PVC COATED. (TENSILE STRENGTH 48000 PSI).

ITEM	POST LENGTH	OUTSIDE DIA(MM)	WALL THICKNESS	WEIGHT Kg/M
LINE POST (SCH80)	3600	88.9	7.62	15.27
CORNER, END AND STRAINING POST (SCH80)	3700	114.3	8.56	22.32
BRACE RAIL (SCH 40)	2800	60.3	3.91	5.44
BRACE STRUT (SCH 40)	3000	60.3	3.91	5.44
TOP RAIL	6000	60.3	3.91	5.44

### FITTINGS

ALL FENCE FITTINGS TO BE HOT-DIPPED GALV. AND PVC COATED AFTER MANUFACTURE IN ACCORDANCE WITH ASTM A-123 AND A-153.

### WIRE PRODUCTS

- WIRE FOR CHAIN LINK FABRIC GALV. AND PVC COATED (BONDED TYPE)
- TENSION, STIRRUP & TIE WIRE GALV. AND PVC COATED (BONDED TYPE)

CLASS	CHAIN LINK FABRIC		TENSION WIRE	TYING WIRE	BARBED WIRE
	MESH	WIRE DIA			
C	50	3.76/ 4.16	4.50/ 4.90	3.76/ 4.16	Ø12.5mm GAUGE 2 STRANDS 4 POINT BARBS AT 125 SPACING

### NOTES

- ALL DIMENSION ARE IN mm, UNLESS NOTED OTHERWISE.
- ALL RESPONSIBILITIES FOR CONCRETE FOUNDATIONS ARE WITH THE CIVIL CONTRACTOR.
- ALL MATERIALS AND DESIGN SHALL BE IN ACCORDANCE TO HIGH COMMISSION FOR INDUSTRIAL SECURITY (HCIS).

APPROVED:	CLIENT:	-
M.Z	FENCE TYPE	2700-B6TR (PVC) CATEGORY-1 WITH 3 ROWS BTC
DESIGNED:	TITLE:	-
F.A		
DRAWN:		
M.T		

**GOLDEN FENCE MECHANICAL FACTORY**  
P.O.BOX 36323 JUBAIL 31961 TEL : +966-13-3408020  
KINGDOM OF SAUDI ARABIA FAX : +966-13-3408022  
INFO@GOLDENFENCE.COM WWW.GOLDENFENCE.COM

DATE	DRAWING NO.	REV.
		A

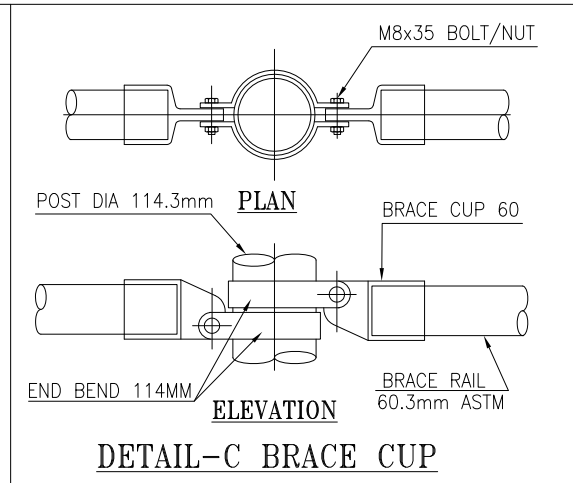
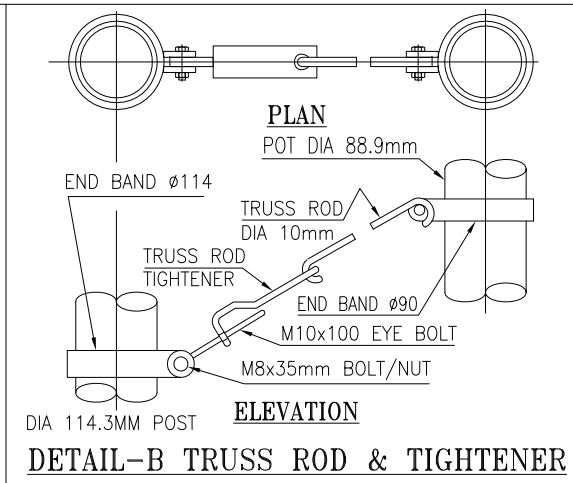
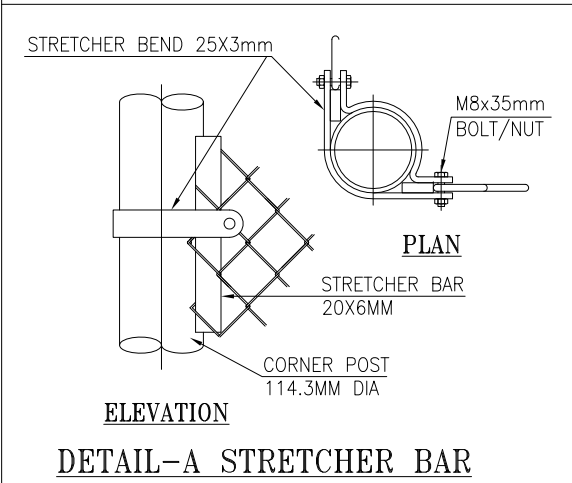
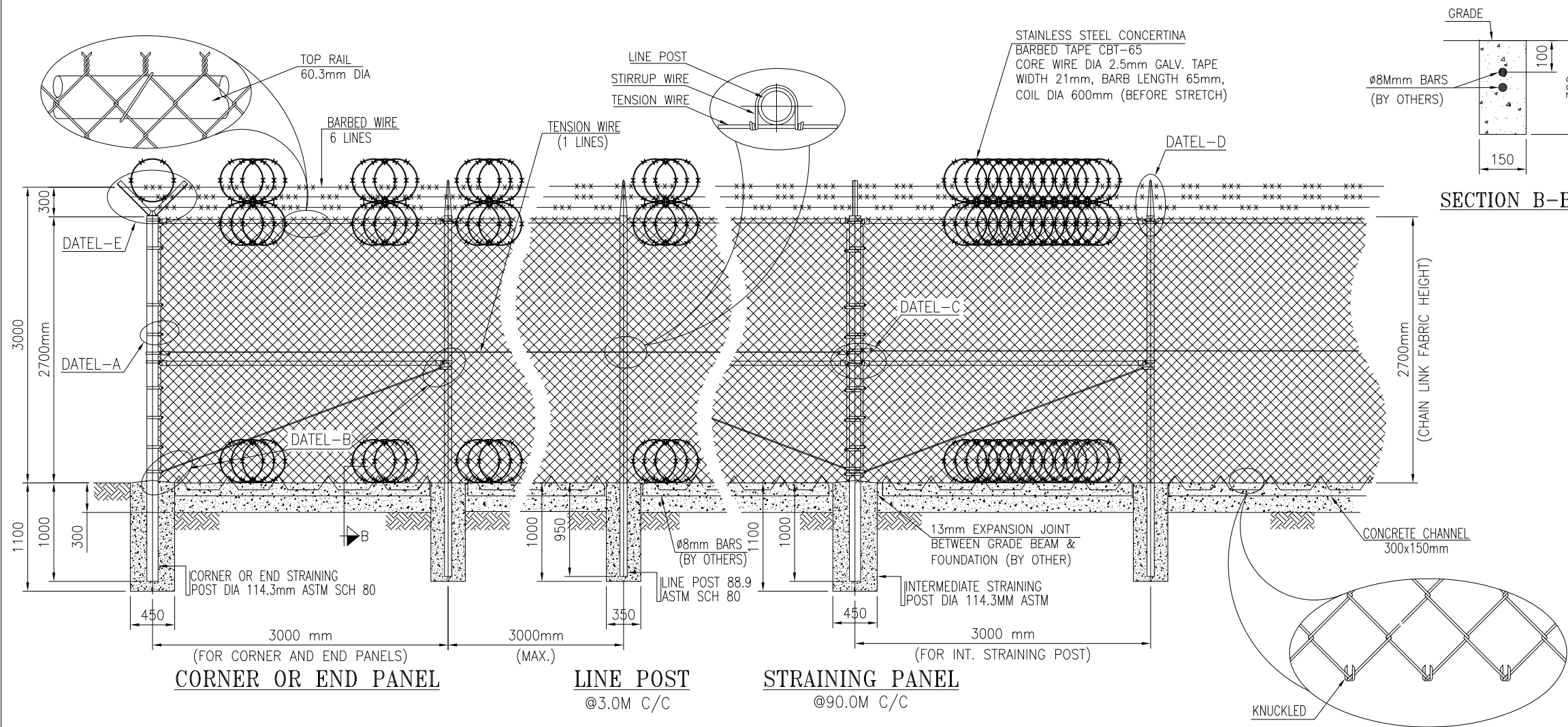

**FINISH : CLASS-C**

- ALL POSTS CONFIRM TO ASTM SCH.8 (TENSILE STRENGTH 85000 PSI) GALVANIZED AND PVC COATED GREEN COLOR.
- DRACE/TOP RAIL AND STRUT PIPE PRODUCTS CONFIRM TO ASTM SCH.40 (TENSILE STRENGTH 48000 PSI) GALVANIZED AND PVC COATED GREEN COLOR.
- ALL FITTINGS HOT-DIPPED GALVANIZED AND PVC COATED GREEN COLOR.
- ALL BOLTS/NUTS GALVANIZED FINISH ONLY.
- CHAIN LINK FABRIC, TENSION, STIRRUPS AND TIE WIRE ARE GALVANIZED AND PVC FUSION BONDED AS PER ASTM F 668 CLASS 2B.
- BARBED WIRE SHOULD BE GALVANIZED FINISH AS PER HIGH COMMISSION INDUSTRIAL SECURITY STANDARD.

